

WM1400-12V

OWNERS MANUAL

Serial No _____ Purchase Date _____

Note - Your Warranty can only be valid once your warranty card is completed and returned to Selectronic Australia



Contents:	Page
<i>INTRODUCTION</i>	4
<i>WARRANTY CARD</i>	4
<i>INSTALLATION</i>	4
<i>SYSTEM DIAGRAM</i>	5
BATTERIES	5
CONNECTION OF AC AND DC WIRING	6
<i>OPERATION</i>	7
MODE BUTTON & LED's.....	7
STATUS & ALARM INDICATORS - LED 5 (green) OFF.....	8
DEMAND START ADJUST - LED 5 (green) ON	8
LOW VOLTS ADJUST - LED 5 (green) FLASHING	9
<i>HANDY HINT</i>	9
<i>FAULT FINDING</i>	10
<i>SYSTEM MAINTENANCE</i>	11
WM1400 MAINTENANCE.....	11
BATTERY MAINTENANCE.....	11
<i>RADIO FREQUENCY INTERFERENCE</i>	12
<i>USING A SELECTRONIC KEYPAD WITH THE WM1400-12</i>	13
SERIAL PORT WIRING.....	13
KEYPAD WIRING.....	13
KEYPAD FRONT PANEL (Display not shown for clarity)	13
STATUS.....	14
READINGS (Keypad Grey Keys)	14
SETTINGS (Keypad Light Blue Keys)	15
OPTIONS (Keypad Light Blue Keys)	16
DIAGNOSTICS (Keypad Light Blue Keys)	16
INVERTER ALARMS	16
<i>WM1400 ELECTRICAL SPECIFICATIONS</i>	17
<i>WARNING</i>	18
<i>PRODUCT WARRANTY and CONDITIONS</i>	19
<i>SELECTRONIC AUTHORISED SERVICE NETWORK</i>	20

INTRODUCTION

Thank you for your purchase of the Selectronic Sine wave inverter, model WM1400-12V. Your WM1400 is a state-of-the-art high performance TRUE SINE WAVE DC-AC Inverter.

Many hours of development time have been invested in the WM1400 so that we can provide you with a reliable high quality inverter. The output from your WM1400 is as good as, if not better than mains power. If looked after properly, the WM1400 will give you many years of reliable service.

WARRANTY CARD

Before proceeding any further, it is extremely important that you complete your warranty card NOW. This will enable us to immediately register your 5 year warranty period. By accurately completing your warranty card, you will provide us with valuable information that will assist us in keeping up with your alternative energy needs. Please take a few moments to fill in the warranty card. Your efforts will be greatly appreciated.

INSTALLATION

The installation of your inverter is extremely important. Failure to follow the recommended installation instructions may void your warranty. If in doubt, ask your supplier.

After unpacking, check for any damage that may have occurred during transit. If there are any signs of damage, contact your supplier immediately.

The Inverter must be installed in a dry, cool, dust-free environment.

Please leave at least 300mm clearance around the sides and top of the Inverter and approximately 200mm at the base as this will aid the natural cooling of the Inverter. The air vents on the underside of the WM1400 also need to be kept clear of obstructions.

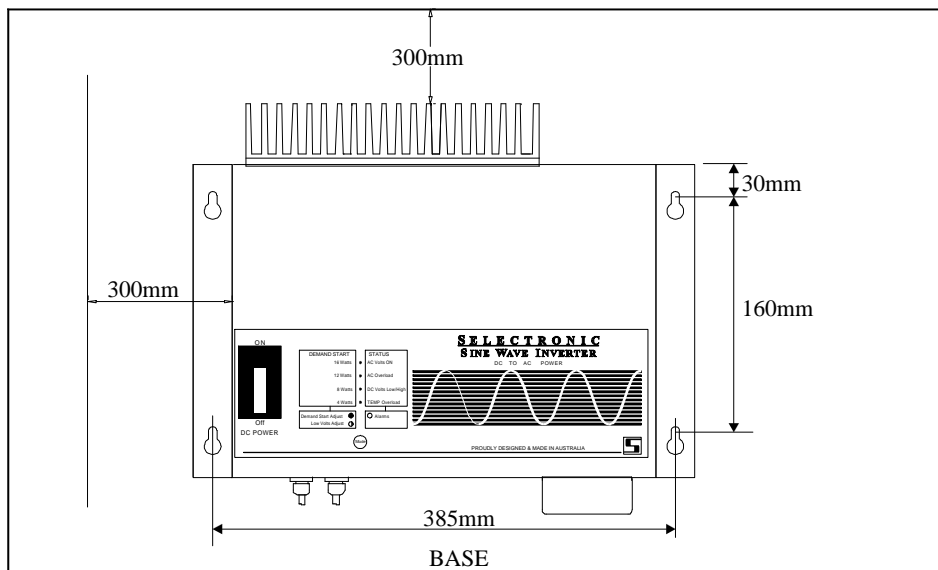

We suggest that you house your Inverter and other power generating equipment in a purpose built shed sited remotely from the home, and as far away as possible from any radio transmitters or receivers. Also make sure that the exhaust from your generator or other sources of heat or fumes are kept well away from the WM1400. SEIA (Sustainable Energy Industry Association (Australia) Ltd) installation guidelines must be followed.

You must have a suitable 12V DC battery bank that is maintained and operated to the battery manufacturer's recommendation. To ensure operation to WM1400 specification, the battery bank should have a minimum capacity of 500 ampere hours at the 100 hour discharge rate 12V systems (ask your supplier if in doubt). Smaller capacity batteries can be used but may result in degraded performance of the WM1400 under heavy surge conditions.

SYSTEM DIAGRAM

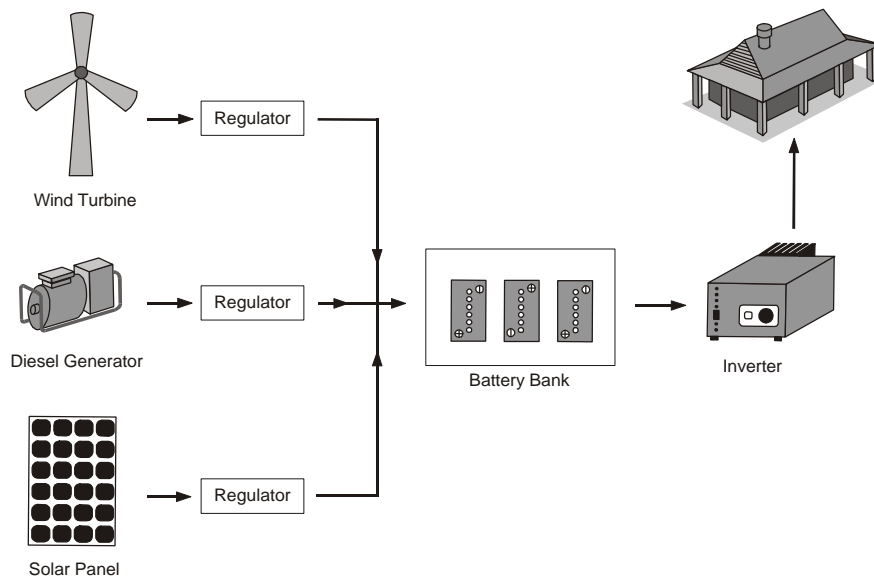

Installation Example

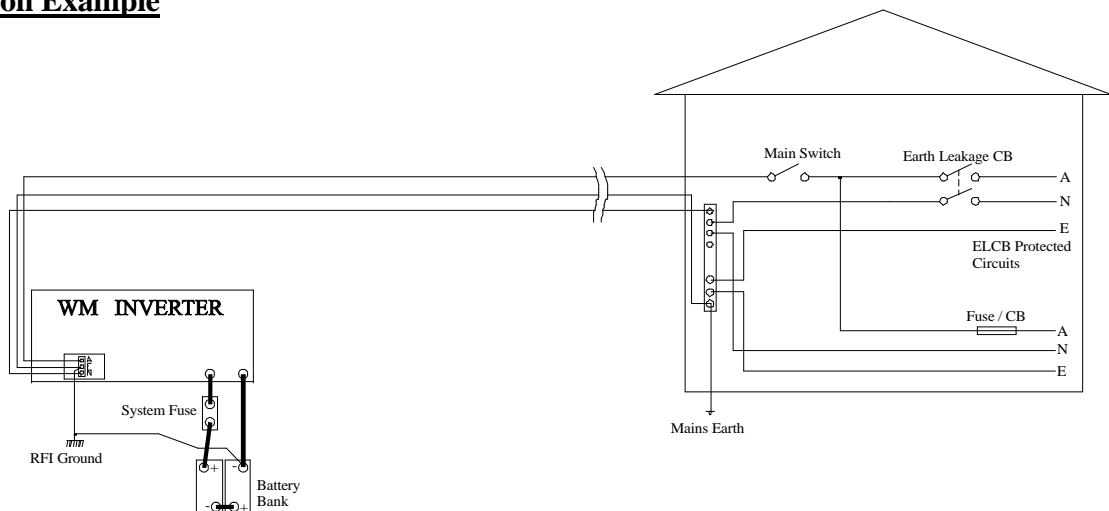

***SYSTEM FUSE**

A system fuse is an extremely important part of any power system, this fuse is designed to give one point of complete disconnect in case of a serious fault. The fuse should have a sufficient rating so as not to blow under heavy load conditions. Your inverter will normally be the biggest load in your system, if this is the case a motor start fuse equal to or slightly higher than the maximum continuous current of the inverter should be used.

If in any doubt see your supplier or installer.

BATTERIES

High quality deep-cycle batteries offer good performance and are available in a wide variety of sizes.

DO NOT USE ordinary car batteries or engine starting batteries. If a battery is rated only in Cold Cranking Amps (CCA) and reserve capacity, it is designed to start an engine. Most hybrid type, wet cell batteries will have a limited life if deeply discharged. These batteries are described as suitable for engine starting or deep-cycle applications. Do not use maintenance free, wet cell batteries. They will not hold up well to deep discharging and repeated cycling.

CONNECTION OF AC AND DC WIRING

IMPORTANT: Before making any wiring connections, check that the circuit breaker on the front panel is in the OFF position, i.e.; LEVER DOWN.

Your electrician should firstly connect the AC wiring via the three terminal junction box. Carefully observe the correct connections. Please refer to the diagram on page 4.

BROWN ACTIVE (red dot, right connector)
 GREEN/YELLOW EARTH (E, centre connector)
 BLUE NEUTRAL (left connector)

The lid of the junction box has knockouts to allow conduit entry. Make sure this connection is tight and safe. Re fit junction box cover.

NOTE:
ALL AC WIRING MUST BE CARRIED OUT BY A LICENSED ELECTRICIAN AND MUST CONFORM TO AS3000 WIRING REGULATIONS, OR RELEVANT STANDARDS.

Verify that the circuit breaker on the front panel is in the OFF position, LEVER DOWN.

Now connect the battery cables.

RED BATTERY POSITIVE (+)
 BLACK BATTERY NEGATIVE (-)

These connections should be tight. If using nuts, bolts and washers, they should be stainless steel. At this point re-check the connections before proceeding any further.

WARNING:

IF THE WM1400 EMITS A VERY LOUD TONE, THE BATTERY LEADS HAVE BEEN CONNECTED IN REVERSE POLARITY. IMMEDIATELY DISCONNECT THE LEADS AND RECONNECT WITH THE CORRECT POLARITY. DO NOT, UNDER ANY CIRCUMSTANCES, TURN ON THE BREAKER WHEN THE BUZZER IS SOUNDING, AS PERMANENT DAMAGE TO THE WM1400 WILL RESULT.

If all is well you can now switch the circuit breaker ON.

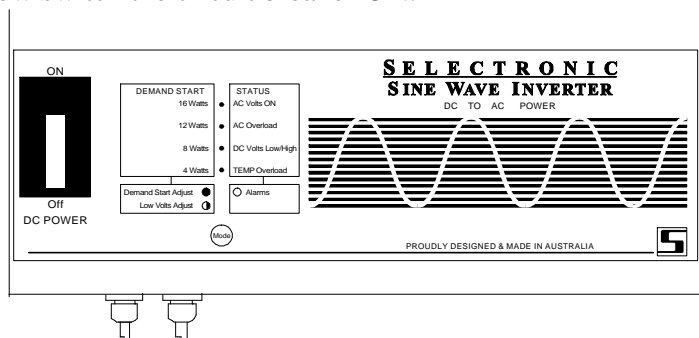

Front Panel

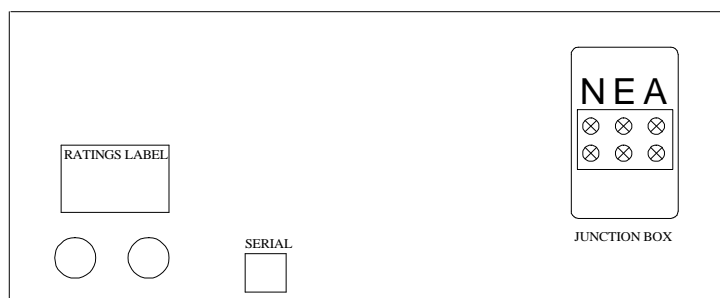

Base

OPERATION

STANDBY mode means that the WM1400 is producing pulses of power to sense when an appliance is switched on. This is called the demand start because as soon as the appliance is switched on, the WM1400 will turn on and provide full power to the appliance. The inverter will drop back into standby mode once all loads have been switched off for longer than 10 seconds. After this time, the WM1400 will return to pulsing or demand start mode waiting for another load to turn on.

This feature is extremely important as it conserves valuable battery power when no appliances are on. The amount of power or load that the Inverter needs to “start up” is adjustable, see page 6 for details.

CONT mode (CONTINUOUS) means that the Inverter will be on at all times regardless of whether appliances are connected or not. This situation is useful if you have small loads such as a VCR or digital clock that requires 24 hour power, or if loads are too small to be sensed in the STANDBY mode. The only disadvantage is that when the appliances are off the WM1400 will be drawing more power than it would in STANDBY mode.

When you first apply power, the WM1400 will be in STANDBY mode. There will be a quiet pulsing sound. The WM1400 is now ready for use.

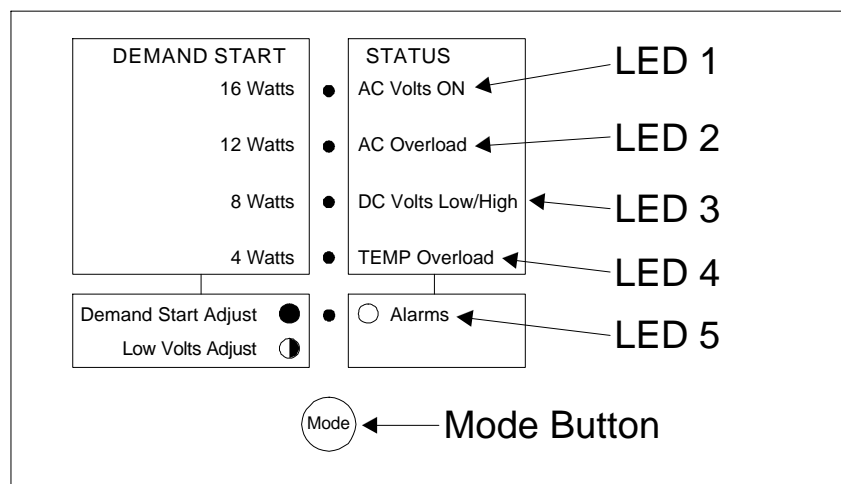

MODE BUTTON & LED'S

The mode button allows adjustment of a number of user adjustable parameters within the WM1400.

Five LED's are provided on the front panel to indicate a number of parameters, and allow adjustment of some of these parameters.

LED 5 tells you what LED 1 – 4 is displaying as indicated on the front panel of the WM1400. Pressing the Mode Button will change the information being displayed.

Please note: Once the parameters have been successfully entered then if the inverter is turned off or the DC power is disconnected from the inverter, the "parameters" which have been entered will be saved and held in permanent memory.

STATUS & ALARM INDICATORS - LED 5 (green) OFF

When power is first applied LED 1 should flash.

When LED 5 is OFF, this indicates the LED (1) – (4) is showing the inverters STATUS, as per written notation to the right of the LED's. In this mode there are no adjustments to be made.

LED 1 Flashing indicates the WM1400 is in Auto Start mode, this indicates that no power is being drawn from the inverter so it has gone to SLEEP to save power. If no power is used within 12 minutes, LED 1 will flash at a slower rate therefore saving more power.

LED 1 Stays ON, the inverter has been commanded to provide power to the load (e.g. a light switch has been turned on) so it has gone from SLEEP mode to ON. Once the load has been removed (e.g. the light switch is turned off) the inverter will wait 10 seconds and return to SLEEP mode.

- It is good practice to have your WM1400 in SLEEP mode as often as possible. When the WM1400 is in SLEEP mode it uses 0.055 amps from the battery, when the inverter is in the ON mode it uses at least 0.6 amps from the battery.

The amount of power required to go from SLEEP to ON is adjustable and is described on below.

LED 2, AC Overload should normally remain OFF. If the inverter shuts down due to too much AC load being drawn from it then LED 2 will come ON. The WM1400 will remain in this condition for 2 minutes after the AC load has been decreased to a safe level. LED 2 will flash if the inverter shuts down due to “time to shutdown”, see page 11.

- If the inverter remains in this condition after two minutes, the main DC Power Switch should be turned OFF and then back ON.

LED 3 DC Volts Low / High should normally remain OFF. If the inverter shuts down because the battery volts are too high then this LED will come ON. It will remain ON until normal battery volts are restored.

- If the inverter shuts down due to not enough battery volts, then LED 3 will flash.
- LED 3 will continue to flash until the battery volts have risen sufficiently. In this case, charge the battery by starting the vehicle or using a battery charger.

The low voltage point that the inverter will cut out is adjustable to suit your particular battery.

LED 4, Temperature Overload should normally remain OFF. If the inverter shuts down due to the heatsink getting too hot, then this LED will come ON. If the inverter shuts down due to the transformer getting too hot, then this LED will FLASH. The inverter will remain shut down until the temperature has lowered to a safe level; the inverter will then come back ON.

- If this LED is coming on regularly, either reduce the amount of load on the inverter or try to move the inverter to a cooler location.

DEMAND START ADJUST - LED 5 (green) ON

It is sometimes necessary to adjust the auto start sensitivity to overcome what is called “Phantom Loads”. A phantom load is a load that tricks the inverter into thinking it should be ON instead of in SLEEP mode.

The wiring of a house or a portable stereo system in standby are good examples of a phantom load. These loads serve no purpose but can increase battery drain by bringing the inverter ON. Hold the Mode button down, (approximately 1 second), LED 5 will turn ON indicating you are ready to adjust this setting. The WM1400 will leave the factory with a setting of **4 Watts**. Now press the Mode button until the desired value is sought. LED's 1 – 4 will return to Status Indication after 10 seconds if a key is not pressed.

- Each press of the Mode Button will increment the Demand Start Level. The adjustment starts from the previously stored setting.

LED 1 - 4, Demand Start Adjustment is indicated by LEDS 1 – 4.

Demand Start Wattage	LED 1	LED 2	LED 3	LED 4
4 Watts				ON
5 Watts			Slow flash	ON
6 Watts			Medium flash	ON
7 Watts			Fast flash	ON
8 Watts			ON	
9 Watts		Slow flash	ON	
10 Watts		Medium flash	ON	
11 Watts		Fast flash	ON	
12 Watts		ON		
13 Watts	Slow flash	ON		
14 Watts	Medium flash	ON		
15 Watts	Fast flash	ON		
16 Watts	ON			
Continuous	ON	ON	ON	ON

After “continuous”, the next button press “rolls back” the demand start setting to 4 Watts

LOW VOLTS ADJUST - LED 5 (green) FLASHING

To avoid total discharging of your battery the WM1400 shuts down at a pre-set low voltage. As all batteries are different, so too is the minimum voltage they should be discharged to. The WM1400 will leave the factory with a setting of **11.0 Volts**, change this setting if required.

From Demand Start Adjust, page 6, hold the Mode button down, (approximately 1 second), until LED 5 is FLASHING, indicating you are ready to adjust this setting. Now press the Mode button until the desired value is sought. LED’s 1 – 4 will return to Status Indication after 10 seconds if a key is not pressed.

Low Volts Cut-out	LED 1	LED 2	LED 3	LED 4
10.0 Volts				ON
10.1 Volts			Slow flash	ON
10.2 Volts			Medium flash	ON
10.3 Volts			Fast flash	ON
10.4 Volts			Fastest flash	ON
10.5 Volts			ON	
10.6 Volts		Slow flash	ON	
10.7 Volts		Medium flash	ON	
10.8 Volts		Fast flash	ON	
10.9 Volts		Fastest flash	ON	
11.0 Volts		ON		
11.1 Volts	Slow flash	ON		
11.2 Volts	Medium flash	ON		
11.3 Volts	Fast flash	ON		
11.4 Volts	Fastest flash	ON		
11.5 Volts	ON			

After “11.5 Volts”, the next button press “rolls back” the Low DC Volts Cut-out setting to “10.0 Volts”

HANDY HINT

It is very important that you become familiar with the functioning of your Inverter. Since most Inverters are not within sight, it is not always easy to know what STATUS your inverter is in. An easy way to determine this is to plug a small child's night-light (neon type) into a power point that is easily visible, or replace any power point with a neon indicator type. This will indicate the inverter's operation by flashing when the inverter is pulsing and remaining on when the inverter is brought on by a load.

FAULT FINDING

1. INVERTER STAYS ON EVEN WHEN NO APPLIANCE IS BEING USED.

Some appliances such as Microwave Cookers or Video Recorders still draw current when not in use. This is to power their displays.

This is a common problem known as a "phantom load", but it can be easily overcome with the WM1400.

When trying to isolate a phantom load these appliances will need to be switched off at the power point. Sequentially switch off appliances at their power points while checking to see if the inverter returns to demand start mode after a 10 second delay. See "Handy Hint" on page 7 if your inverter is located remotely. Once you have found the offending appliance, adjust the sensitivity of the demand start up (see page 6) until the Inverter turns off. Once this is done re check that small loads will still bring the Inverter on when required.

2. INVERTER WILL NOT COME ON WHEN SMALL APPLIANCE IS SWITCHED ON.

This means that your demand start sensitivity is set too high. With the appliance in question switched on, adjust the demand start sensitivity (see page 6) until the WM1400 turns on.

3. INVERTER SHUTS DOWN DURING MIDDLE OF THE DAY AND COMES BACK ON LATE AFTERNOON.

This is more than likely caused by high battery volts during peak charging times from solar panels. Battery volts should never exceed 17 volts. If this is the case, have your Solar Regulator checked. This could be potentially dangerous so we advise you to consult your system designer immediately.

4. INVERTER SHUTS DOWN WITH LOW VOLTS.

If your WM1400 has shut down because of low DC volts it could be due to the following:

- (1) A sustained large load could be causing the battery volts to drop below the cut out voltage.
 - (a) The Battery Bank is too small for the loads you wish to use - consult your system designer.
 - (b) A bad connection between the batteries and inverter due to a loose or corroded terminal. In this case, please refer to the maintenance section of this manual.
 - (c) One or more battery cells could be faulty - consult your battery supplier.
- (2) If your battery volts are below 12.0V with no loads connected, the batteries may require charging. Use a hydrometer to check the specific gravity of each cell. Consult your battery manual for the correct specific gravity (SG) readings.

5. INVERTER SHUTS DOWN DUE TO HS TOO HOT

This is likely under sustained heavy load conditions since the WM1400 shuts down to protect its internal components. If you believe that the load is not excessive, check around the Inverter case and heatsink for obstructions to airflow as this will cause the Inverter to heat up much quicker and shut down sooner than normal. Also check that the clearances around the WM1400 are as specified in the INSTALLATION section of this manual.

6. INVERTER PULSES SLOWER THAN NORMAL WHEN IN STANDBY

This means that the inverter has not been switched on for approximately 20 minutes and has gone into a power saving mode, thus pulsing at about half the normal rate.

SYSTEM MAINTENANCE

To get the optimum performance from your WM1400 power inverter, particularly under heavy appliance loads, it is essential that the battery bank and the DC wiring are all in good condition. The small amount of time spent on the maintenance tasks below will maximise the reliability of your system.

WM1400 MAINTENANCE

Periodic maintenance of the WM1400 inverter involves little more than checking for unobstructed operation of the cooling fans, which are located on the sides of the inverter. Note that cooling air is drawn in through the vents in the side of the inverter.

Suggested inverter maintenance should include:

1. Check for unobstructed fan operation:
Clear away any dust or foreign matter from the fan grill using a soft bristled brush.
(Do not direct high-pressure compressed air at the fan blades)
Note that the fan is designed to come on during heavy power demand.
2. Check between fins of the heatsink and clean out any accumulated foreign objects, for example, insect nests.

BATTERY MAINTENANCE

IMPORTANT:

When working on batteries of such high capacity it is essential that you wear protective clothing, some form of eye protection and rubber-soled work boots. Please regard your batteries with a great deal of caution, and if in any doubt, entrust this work to your installer.

1. Every week, carry out a thorough visual inspection of all battery wiring, taking particular note of the condition of inter-connections between cells.
2. Check that the stainless steel inter-connecting bolts are tight and have minimal corrosion. If corrosion is evident, carefully follow the following procedure.
 - (a) Disconnect the system battery fuse before working on the battery bank.
 - (b) Unbolt the stainless steel bolts and nuts of any corroded connections and thoroughly clean the joint with a wire brush or file, taking extreme care not to short circuit any battery cells with any tools.
 - (d) Re-assemble and smear a small amount of Vaseline or similar grease over the surface of the joint to slow down any future corrosion.
3. Every month or as directed in your battery instruction manual, measure the specific gravity (SG) of each cell using your hydrometer, to ensure that all cells are performing correctly. Any serious imbalance should be reported to your system designer in case remedial action needs to be taken.

RADIO FREQUENCY INTERFERENCE

Radio Frequency Interference (RFI) can be a problem for owners of inverters. RFI in a domestic situation may produce noise or interference on a radio or TV receiver.

Considerable development time has resulted in a reduction of the RFI generated by the inverter to a level that complies with C-tick requirements. Compliance to this standard means RFI is low, but how well the inverter performs in a particular installation can vary. Below are some suggestions to help reduce the effects of RFI in your installation;

- It is recommended that the power system, including the inverter, be housed at least 15 metres from the home.
- Ensure an earth stake is placed as close to the inverter as possible and connected to the inverter via a short length of wire. See the “INSTALLATION” section of this manual for wiring.
- Avoid running DC cables into the home, if at all possible. If this cannot be avoided, run DC and AC in separate conduits separated by as much distance as practicable. All DC wiring cables should be kept together and be as short as possible.
- If your inverter is to be installed in a Mobile Home or similar, try to keep your inverter at least one metre away from your radio or audio equipment. The further the better.

USING A SELECTRONIC KEYPAD WITH THE WM1400-12

SERIAL PORT WIRING

Serial Port Pin Number	Data Cable Wire Colour	Function
1	White with green stripe	Transmit +
2	Green	Transmit -
3	White with orange stripe	Receive +
4	Blue	+15V
5	White with blue stripe	0V
6	Orange	Receive -
7	White with brown stripe	
8	Brown	

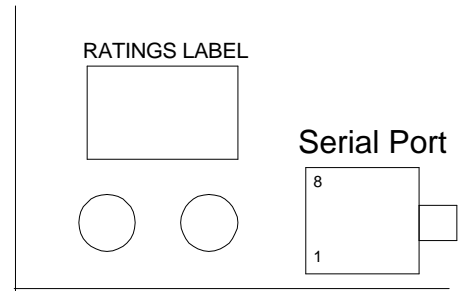

KEYPAD WIRING

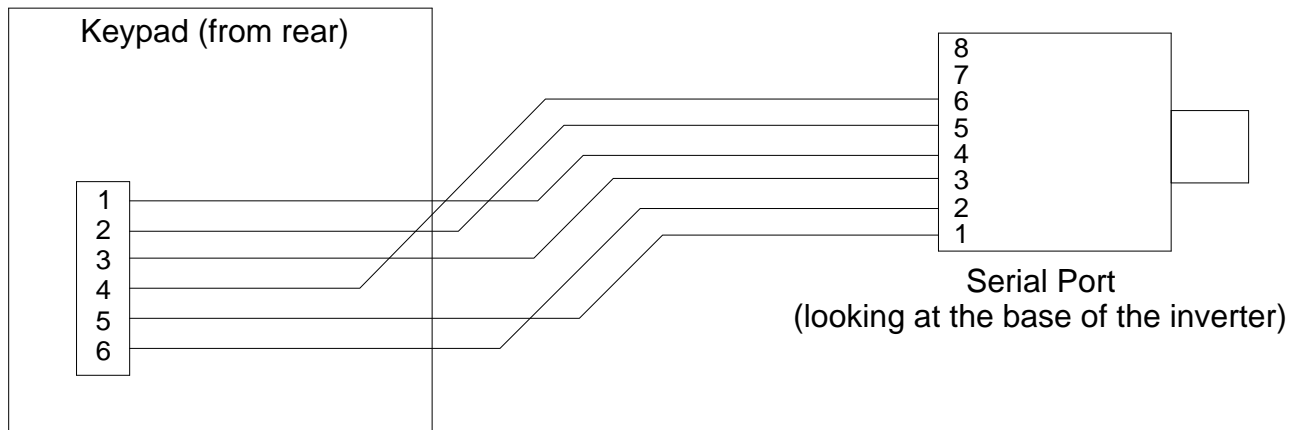

KEYPAD FRONT PANEL (Display not shown for clarity)

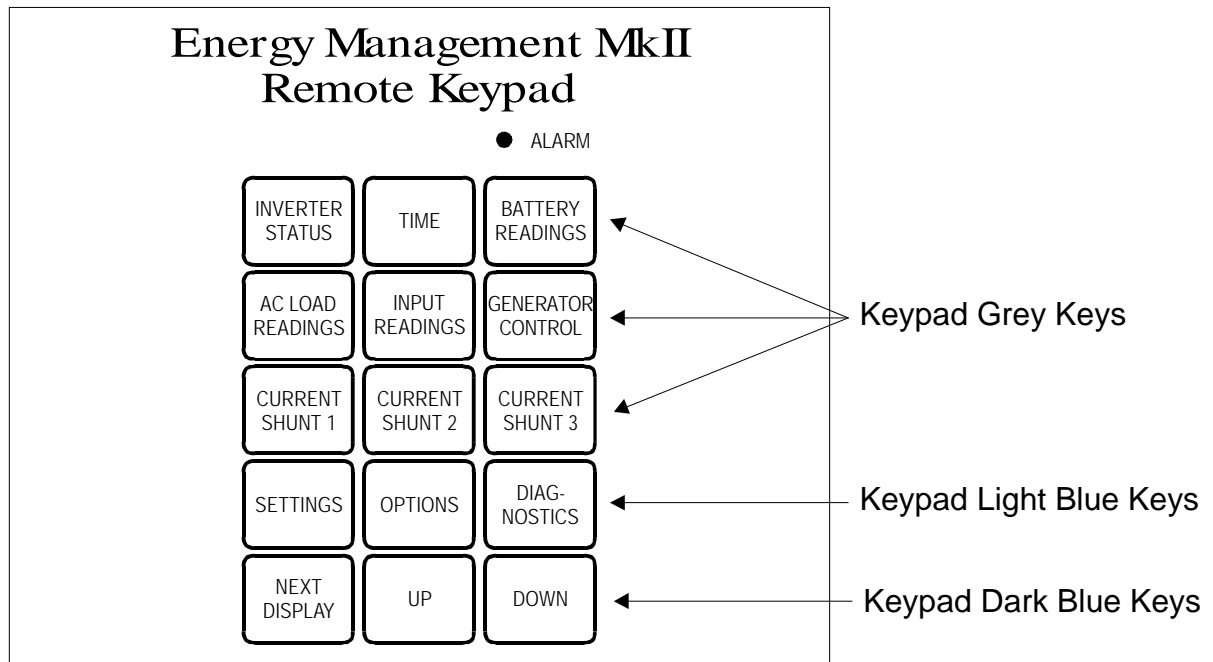

STATUS

When you turn on the WM1400 with a keypad installed, the keypad screen will be displayed. Press NEXT DISPLAY twice.

```
Press NEXT twice
WM1400 1.00 2000
```

The inverter STATUS will be displayed. The inverter can have one of three status conditions. When first turned on it will show STANDBY mode.

```
Status: STANDBY
Inverter: ON
```

```
Status: CONT
Inverter: ON
```

```
Status: RESET
Inverter: OFF
```

When this screen is displayed, the Status can be changed by pressing the UP or DOWN arrow keys. Each time the UP key is pressed, the status will change from STANDBY to CONT to RESET and back to STANDBY where the DOWN key will change the Status in the reverse order.

The second line indicates if the inverter is ON or OFF. When ON the inverter is supplying 240V mains power. During standby, OFF is displayed on the second line, reverting to ON when a load is sensed and the inverter starts.

STANDBY mode means that the WM1400 is producing pulses of power to sense when an appliance is switched on. This is called the demand start because as soon as the appliance is switched on, the WM1400 will turn on and provide full power to the appliance.

The inverter will drop back into standby mode once all loads have been switched off for longer than 10 seconds. After this time, the WM1400 will return to pulsing or demand start mode waiting for another load to turn on.

This feature is extremely important as it conserves valuable battery power when no appliances are on. The amount of power or load that the Inverter needs to “start up” is adjustable, see page 5 for details.

CONT mode (CONTINUOUS) means that the Inverter will be on at all times regardless of whether appliances are connected or not. This situation is useful if you have small loads such as a VCR or digital clock that requires 24 hour power, or if loads are too small to be sensed in the STANDBY mode. The only disadvantage is that when the appliances are off the WM1400 will be drawing more power than it would in STANDBY mode.

RESET mode electronically shuts down the inverter. When placed in this mode, any overload or shutdown conditions are also reset. This situation will be explained in more detail in a later section.

READINGS (Keypad Grey Keys)

The displays provide the following information: Press the indicated Keypad Grey Key.

Battery Readings

```
DC Volts:13.7V
--- Readings ---
```

Displays the DC Battery volts. This provides you with an indication of the condition of your battery bank.

AC Load readings

```
AC Volts : 240V
--- Readings ---
```

This reading gives an indication of the AC voltage produced by the inverter. This reading will vary depending on how large a load is connected or if the battery voltage is very low. Pressing the AC LOAD READINGS button again will move you to the next “AC Amps” screen.

AC Load readings (second button press)

AC Amps : 2.5A
--- Readings ---

The AC Amps reading shows the total current drawn from the AC output by the appliances connected to the inverter. This reading is also handy for knowing how much power a particular appliance draws. Pressing the AC LOAD READINGS button again will move back to the previous "AC Volts" screen.

Other Keypad grey keys

Not Installed

Pressing any of the keys "TIME", "GENERATOR CONTROL", "INPUT READINGS", "CURRENT SHUNT 1", "CURRENT SHUNT 2", "CURRENT SHUNT 3", will result in this screen being displayed. The functions are not available on the WM1400

SETTINGS (Keypad Light Blue Keys)

Press the Keypad SETTINGS Light Blue Key, then the ENTER Dark Blue Key.

Please note: Once the parameters have been successfully entered (i.e. you have stepped right through the set parameters menu) then if the inverter is turned off or the DC power is disconnected from the inverter, the "parameters" which have been entered will be saved and held in permanent memory.

KEYPAD BUZZER

Buzzer : ON
-Set Parameters-

This display allows you to select whether the keypad audio alarm will sound during an overload or other alarm condition. Use the UP or DOWN keys to toggle between ON or OFF state. This is set to ON at the factory.

DS SENSE

DS Watts :12W
-Set Parameters-

Demand Start: When in STANDBY mode the inverter will require a load of 4 watts or greater to turn on to full 240V power. This setting can be adjusted between 4 to 16 watts. In most cases the default setting of 4W would be suitable. If there is a load which the WM1400 won't sense then increase this value until the WM1400 goes into demand start (pulsing mode). You may need to try a few different settings to find the most appropriate value for your installation. Use the UP or DOWN keys.

LO DC VOLTS

Lo DC Volts:11.0
-Set Parameters-

The WM1400 will cut out and a message will be displayed if the battery voltage falls below this setting for more than 10 seconds. The inverter will restart if reset, or when the battery volts rise above 11.5V. Use the UP or DOWN keys to change the value. Default values are 11.0 volts for 12V operation.

AC OUTPUT VOLTS

AC Volts : 240V
-Set Parameters-

Allows the AC output voltage to be set in a range of 220V to 240V if an output voltage other than 240V is required. Users outside Australia should check with their system designer for the correct setting. Use the UP or DOWN keys to change the value. This value is set to 240V at the factory.

END SETTINGS

-End-
-Set Parameters-

Indicates the end of the set parameters menu. Press any grey keypad key to return you to the STATUS menu and save your settings.

OPTIONS (Keypad Light Blue Keys)

Press the Keypad OPTIONS Light Blue Key.

```
-END-  
--Alarms--
```

This display allows access to logged alarms.

Press the OPTIONS key to scroll through logged alarms.

If there are no logged alarms, only this screen will be displayed.

When in this END ALARMS screen, press any grey keypad key to return you to the STATUS menu.

Logged alarms are:

- Low DC Volts
- High DC Volts
- AC Current Overload
- Current Limit
- High Transformer Temperature
- High Heatsink Temperature

DIAGNOSTICS (Keypad Light Blue Keys)

Press the Keypad DIAGNOSTICS Light Blue Key.

The following screens allow the user to look at various internal inverter values. These are not able to be changed from the keypad.

```
Press NEXT key  
..Diagnostics..
```

Press the NEXT key to access diagnostics screens.

```
Tx Temp.: 1  
..Diagnostics..
```

Indicates transformer temperature. Note the reading is NOT in degrees Celsius.

```
HS Temp: 53C  
..Diagnostics..
```

Indicates Heatsink temperature. Note the reading IS in degrees Celsius.

```
D/S I: 2  
..Diagnostics..
```

Indicates Demand Start current level.

```
Selectronic C  
WM1400 1.00 2000
```

Indicates the Inverter model, microprocessor code revision and year.

Press any grey keypad key to return you to the STATUS menu.

INVERTER ALARMS

Inverter Alarms are not indicated on the keypad screen. The status of the inverter can be checked, along with the output voltages and currents.

The Keypad LED will flash and the buzzer will sound on an Inverter Alarm.

WM1400 ELECTRICAL SPECIFICATIONS

INVERTER TYPE

PWM Full Bridge power stage, with true sine wave AC output.

SELECTRONIC WM1400 INVERTER SPECIFICATIONS		
ELECTRICAL		
PARAMETER	WM1400	CONDITION
Output Power @ 25 °C Ambient	1,400 watts 1,800 watts 3,600 watts	Max Continuous 1/2 Hour Rating Max Surge
Output Power @ 40 °C Ambient	1,200 watts 1,600 watts 3,600 watts	Max Continuous 1/2 Hour Rating Max Surge
Voltage Input Range	10 - 17V DC	Range
Input Current	0.05A DC 0.7A DC 136A DC 349A DC	Stand By Inverter ON – No Load Max Continuous 25°C Max Surge 25°C
Demand Start Sensitivity Response Time Factory Setting	4-16W 1 Second Max 4W	User Adjustable Factory Setting
Low Voltage Shutdown High Voltage Shutdown Factory Setting (Low Voltage Shutdown)	10 – 11.5V DC 17V DC 11.0V DC	User Adjustable Fixed Factory Setting
Output Voltage	240V AC +/- 4%	@ Nominal DC Input, No Load to Full Load
Output Current	5.8A AC 15A AC	Max Continuous Max Surge
Output Wave Shape	True Sine Wave	
Output Frequency	50Hz +/- 0.01%	
Total Harmonic Distortion	< 4%	
Efficiency	Peak 91% Full load 85%	
Power Factor Limitations	Nil	
Input / Output Isolation	1,875VAC	
Memory Retention	Permanent	
Operating Temperature Range	-10 °C to 50 °C	
Conforms to standards	AS 3100 (wiring), AS 3108, C tick	
MECHANICAL		
Size	410mm wide x 175mm high x 342mm deep	
Weight	14kg	
Weight Packed	17kg	
Input Lead Length	1.5 metres	
Output Wiring Method	Three terminal junction box with conduit knock outs	
Chassis	Powder coated zinc steel (Wedgwood Blue)	
DC Isolation	Single Pole Circuit Breaker (Non auto)	
Warranty	5 year parts and labour (Conditions apply)	

Notes:

The above specifications are based on unity power factor.

The DC Input is electrically isolated from the AC Output.

Through a policy of continued development, specifications are subject to change without notice

WARNING

**THE OUTPUT VOLTAGE FROM AN INVERTER IS JUST AS
LETHAL AS LANDLINE POWER.**

It is necessary for your safety to ensure that all Remote Area power system installations meet and comply with the relevant provisions and requirements of AS3000 wiring standards and AC wiring is installed by a Registered Electrical Contractor.

PRODUCT WARRANTY and CONDITIONS

These warranty conditions apply to the WM, SE and SA range of Inverters for sales within Australia and New Zealand.

This product is warranted by the manufacturer for a period of 60 months from date of purchase to the original purchaser only.

The manufacturer will bear the cost of parts and labour to repair any faults found within the terms and period of this warranty.

Faulty product or parts must be returned to Melbourne Australia at the owner's expense for claim under warranty. No allowance is made for the cost of labour or traveling time required to disconnect or reinstall faulty parts.

Cost of freight to return parts to the customer will be paid by the manufacturer, method of freight used will be determined by the manufacturer.

Under certain circumstances the manufacturer may allow on site repairs to be carried out. This will be at the manufacturers discretion and the manufacturer is not responsible for the cost of any labour or traveling time incurred.

Unless otherwise specified to the purchaser the benefits conferred by this voluntary warranty are additional to all other conditions, warranties, guarantees, rights and remedies expressed or implied by the Trade Practices Act in your state or territory.

All installation and user conditions as set down in the instruction manual must be strictly adhered to, failure to do so may void your warranty.

This product is not to be used for Life Support equipment.

Any faults caused by lightning, water or moisture ingress, faulty installation, using the product in a manner which it is not intended, vermin infestation, improper voltage, alterations to the product which affect its reliability or performance, or faulty generator sets will not be covered under warranty.

The manufacturer shall bear no responsibility for any consequential loss, damage or expense due to any malfunction of the product or the time it is out of service

The manufacturer will not be held responsible for any misleading or incorrect information conveyed by any salesperson or installer not directly employed by the manufacturer.

If service is required please contact your installer or retailer before taking any further action.

SELECTRONIC AUTHORISED SERVICE NETWORK

Selectronic Australia
Suite 5, 20 Fletcher Road
Mooroolbark
Victoria 3138
Australia
Ph: +61 3 9727 6600
Fax: +61 3 9727 6601
www.selectronic.com.au
service@selectronic.com.au

Burley TV Service
278 Edmondson Ave.
Austral
NSW 2171
Australia
Ph: 02 9606-0279

Rainbow Power Company
1 Alternative Way
Nimbin
NSW 2480
Australia
Ph: 02 6689 1430
Fax: 02 6689 1109

Solar Inverter Services
13 Thirteenth Ave.
Sawtell
NSW
2452
Ph: 02 66581733

Reid Technology Ltd
3-5 Auburn Street
Takapuna
North Shore City
Auckland NZ
Ph: 9 489-8100
Fax: 9 489-8585
ps@reidtechnology.co.nz



Suite 5, 20 Fletcher Road Mooroolbark Victoria 3138 Australia
Phone +61 3 9727 6600 Fax +61 3 9727 6601
Web www.selectronic.com.au **Email** sales@selectronic.com.au